



the  
**LatimerArts**  
College

# **Year 8 Key Stage 4 Pathways 2023**

## **Key Information & Subject Pages**

# Contents

	<b><u>Page</u></b>
<b><u>Key Information</u></b>	1-2
<b><u>Core Subjects</u></b>	
Cultural Studies	3
GCSE English Language	4
GCSE English Literature	5
GCSE Mathematics	6
Physical Education	7
GCSE Science Trilogy	8
<b><u>EBacc Choices</u></b>	
GCSE French	9
GCSE Geography	10
GCSE History	11
<b><u>Option Choices</u></b>	
GCSE Art, Craft & Design	12
GCSE Computer Science	13
GCSE Dance	14
GCSE Design & Technology	15
GCSE Drama	16
GCSE Food Preparation & Nutrition	17
GCSE Music	18
GCSE Philosophy & Ethics	19
GCSE Physical Education	20
GCSE Psychology	21
GCSE Science Triple Award	22
BTEC Business Studies	23
BTEC Creative Digital Media Production	24
BTEC Sport	25

# Routes to Success

At The Latimer Arts College, at Key Stage 4 we provide every student with a basic core curriculum, which includes English, Mathematics, Science, Physical Education and Cultural Studies.

Students will complete their personalised curriculum by expressing preferences for four additional subjects that they wish to study. This will result in them securing 9 Level 2 qualifications in total.

Students and their parents/carers should consider these preference choices carefully. Once a student has expressed their preferences, every effort is made to enable them to study the courses that they would like to. **Preference choices cannot be altered once they have been confirmed.**

**Please note that students are expressing a preference and no guarantees are made at this time.** The College will do its best to provide each student with their preferred subjects. However, should courses be oversubscribed a **lottery** system will be used to select students for the available places. Should a course be undersubscribed, it may not run.

## The English Baccalaureate (EBacc)

The **EBacc** is made up of 5 GCSE qualifications including English, Mathematics, Science, a Modern Foreign Language (French) and a Humanities subject (Geography or History).

We strongly recommend this pathway, which is well regarded, for most students. Students wishing to take this pathway **must** choose French as a preference.

## Key dates

Below is an outline of the support, information and guidance Year 8 students will receive during the Pathways process and beyond

Event	When	Purpose
Year 8 Key Stage 4 Pathways Assembly	Monday 13 <sup>th</sup> March	To explain the pathways process to students
Year 8 Key Stage 4 Pathways Showcase Evening	Tuesday 21 <sup>st</sup> March, 5.30pm - 8.00pm. You will be invited to a timed slot.	To explain the pathways process; opportunity for parents and students to speak to GCSE and BTEC teachers
Key Stage 4 Subject Information Sessions	w/c Monday 20 <sup>th</sup> March	For students to find out information about subjects, course content, skills learnt, career pathways
Key Stage 4 Subject Taster Sessions	w/c Monday 27 <sup>th</sup> March	For students to experience a taster session in GCSE and BTEC subjects
Year 8 SPRE	Wednesday 26 <sup>th</sup> April, 4.30-7.45pm	To discuss students' progress. An opportunity to have final discussions about pathway choices

**Deadline for subject preference forms to be completed: Thursday 27<sup>th</sup> April 2023**  
All students will receive confirmation of their places later on in the school year.

# Preference Columns

Core Column:	Preference 1:	Preference 2:	Preference 3:	Preference 4:
GCSE English Language	GCSE Geography	GCSE Computer Science	GCSE Art	GCSE Dance
GCSE English Literature	GCSE History	GCSE Design and Technology	<b>GCSE French</b>	<b>GCSE French</b>
GCSE Mathematics		GCSE Drama	GCSE Music	GCSE Philosophy and Ethics
GCSE Science Trilogy		GCSE Food and Nutrition	GCSE Psychology	GCSE Physical Education
Core PE		<b>GCSE French</b>	BTEC Business	<b><u>GCSE Triple Science</u></b>
Cultural Studies		GCSE Geography	BTEC Media	BTEC Business
		BTEC Sport		BTEC Media
				BTEC Sport

To meet the requirements of the **EBacc pathway**, students must select French in one column.

\*GCSE Triple Science (***shown in bold and italics***) has demanding academic content. During the Pathways fortnight, students who want to apply to study this subject need to speak to their Science teacher or Mrs Cook in order to confirm their suitability.

Those wishing to apply to GCSE Physical Education must have a conversation with Mr Hallett about their suitability.  
GCSE Design and Technology and GCSE Food and Nutrition have limited places.

**GCSE:** These courses are assessed by terminal examinations which occur at the end of Year 11. A few subjects still contain an element of controlled assessment which is completed in class and contributes to the final grade. Details for each course can be found in the subject pages.

**BTEC:** These courses are technical qualifications. The qualifications are assessed by a combination of portfolio work completed throughout the course and external examinations. They are equivalent to GCSE qualifications. Details for each course can be found in the subject pages.

# Cultural Studies (Core)

## Overview

Cultural Studies is a core subject at Latimer and covers a wide range of topic areas in line with the National Curriculum Requirements. We aim to support and enable our students in developing the ability to make their own reasoned and informed judgements about the religious and moral issues which arise from reflection on human experience and a study of religious and non-religious beliefs and practice. We aim for students to consider ways in which beliefs, values, traditions and current affairs might have significance for their own lives.

Opportunities to develop spiritual, moral, social and cultural issues are explored. Encouraging students to think, discuss and debate thought provoking topics. It helps develop speaking and listening skills whilst it also encourages students to be respectful of other people's opinions, beliefs and practices.

We draw upon a wide range of stimulus for discussion points including role play, hot seating, film clips, art, visitors, IT, music, poetry and artefacts.



## Course Content

Students will have a wide and varied curriculum on offer throughout their three years of Cultural Studies. Each year, each unit of study is updated to ensure the most current and up-to-date case studies are used throughout the course. This supports students' general knowledge and is applicable to many of their examined courses. Students will study and debate exciting topics which impact the world they live in such as:

Extremism and Radicalisation

Religion/Ethics in the Media

Poverty and Wealth

Justice and Equality

Relationships

Matters of Life & Death

Social Issues

Holocaust

**For more information please speak to Mrs Murdoch**

# GCSE English Language (Core)

## Overview

All students will study the new specification for GCSE English Language.

The English Language course offers a range of opportunities for students to develop the necessary literacy skills for the 21st Century; reading, understanding and analysing a wide range of different texts and writing clearly and creatively for a purpose.

## Course Requirements

Students will be required to read a range of non-fiction, literary non-fiction and fiction from the 19<sup>th</sup>, 20<sup>th</sup> and 21<sup>st</sup> Century. They will then be required to answer a series of short-form, long-form and extended questions testing their understanding of the writer's linguistic and structural presentation of key ideas and themes.

Students will then craft their own well written and creative text following a similar theme to the sources read, to a specific purpose, audience and format getting marked for their content and technical accuracy.

## Course Content

Units for these courses will include the teaching of skills, strategies, walk-through mocks and mocks of the exams' structures which are as follows:

### **Paper 1: Explorations in creative reading and writing. (1 hour 45 mins)**

- **Section A** – One literature fiction text.
- **Section B** – Descriptive or Narrative writing

### **Paper 2: Writers' viewpoints and perspectives.**

- **Section A** – one non-fiction and one literary non-fiction text.
- **Section B** – Writing to present a viewpoint



## Method of Assessment

Students will be constantly assessed over the two year course in these reading and writing skills.

There is an endorsed component covering Spoken Language (a Speaking and Listening assessment) that will be completed in school under controlled conditions. This will test the student's verbal presenting, response to questions and feedback and use of Standard English. This endorsement will be reported as a separate grade (Pass, Merit, Distinction or Not Classified) and will not contribute to the result of the English Language GCSE but is necessary for its completion.

Paper 1 and Paper 2 are both worth 50% respectively of the English Language qualification and will be tested by external examinations at the end of the course.



For more information please speak to Mr Nunney

# GCSE English Literature (Core)

## Overview

This course will help students to explore, analyse and appreciate a wide range of contemporary and heritage texts. The study of the English Literature texts span across genres of poetry, prose and drama and will take an immersive and historicist approach.

## Course Requirements

Students will be required to analyse, interpret and compare a variety of texts. The historical, social and cultural context of 16<sup>th</sup> - 20<sup>th</sup> Century Britain will be studied alongside texts, complementing and enhancing the study of the Literature texts. The skills of close analysis, extract study, approaching unseen poetry, structural consideration and whole text appreciation will be honed across the course alongside students developing their own critical 'voice' and confidence in essay writing.

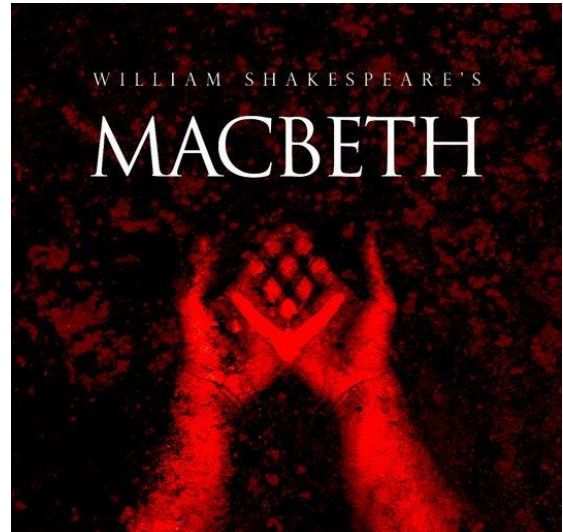

## Course Content

Units for this course will include:

- 19<sup>th</sup> Century Novel – currently Arthur Conan Doyle's *The Sign of Four*
- Shakespeare – currently William Shakespeare's *Macbeth*
- Poetry – currently Love and Relationships Cluster (15 poems) and approaches to Unseen Poetry.
- Modern Text – currently J. B. Priestley's *An Inspector Calls*

**Paper 1 – Shakespeare and the 19<sup>th</sup> Century Novel - 40% of qualification.**

**Paper 2 – Modern Texts and Poetry - 60% of qualification.**

**For more information please speak to Mr Nunney**

# GCSE Maths (Core)

## Overview

In Year 9, students will continue to follow the AQA 1-9 GCSE course with the tier of entry being determined by the results obtained up to the end of year 8. Higher tier (GCSE Grades 4 to 9 available) or the Foundation tier (GCSE Grade 1 to 5 available). This will be reviewed on a regular basis through assessment and monitoring of progress. In year 11 they will complete their studies and results will be solely based on the terminal examination.

## Course Content

All students will be taught the topics relating to the areas of shape, algebra, number, proportion and statistics. A scientific calculator and maths set is required for all lessons.



## Method of Assessment

There will be an examination in May or June of year 11. This will consist of three papers, two of which are calculator papers and one non-calculator paper. Each paper has an equal weighting and last for 1 hour 30 minutes. Students will be entered for the appropriate level in discussion with the teacher. There is no coursework.

## Useful revision websites.

- [www.HegartyMaths.com](http://www.HegartyMaths.com)
- [www.corbettmaths.com](http://www.corbettmaths.com)
- [www.DrFrostMaths.com](http://www.DrFrostMaths.com)

## Revision guides

AQA GCSE Maths Higher All-in-One  
Revision and Practice (Collins)

ISBN-10: 0008112509 ISBN-13: 978-  
0008112509

AQA GCSE Maths Foundation All-in-One  
Revision and Practice (Collins)

ISBN-10: 0008112517 ISBN-13: 978-  
0008112516

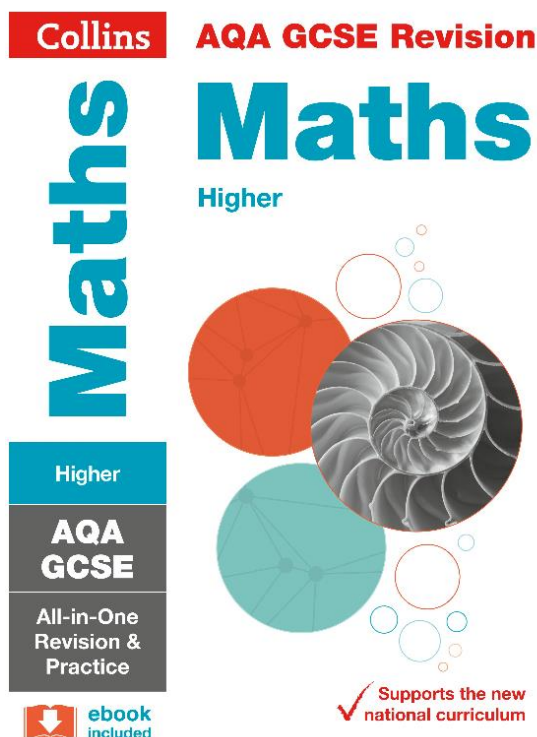

**For more information please speak to Mr Wall**



# Physical Education (Core)

## Overview

Physical Education remains a compulsory subject in Years 9, 10 and 11 and all students have two hours of curriculum time a week. The emphasis in core P.E is on participation and enjoyment to promote a prolonged interest in sport and physical activity whilst making progress across a range of sports.

Students will cover a variety of sports across six areas:

Athletics  
Games  
Gymnastics  
Health and Fitness  
Net/Wall  
Striking and Fielding

Sports covered on the curriculum over the three years include Athletics, Football, Basketball, Rugby, Hockey, Volleyball, Gymnastics, Health and Fitness, Badminton, Table Tennis, Tennis, Cricket, Rounders and Softball.



New and innovative sports are also introduced to students to inspire them to continue sport and exercise outside of the curriculum with Flag Football, Stool Ball, Futsal and Dodgeball being introduced to the students too.

The P.E curriculum is supported by an extensive Extra-Curricular programme across all year groups with opportunities for students to continue their progress in their chosen sports as well as the opportunity to represent the college in fixtures.

The department pride themselves on offering opportunities for students to engage in an exciting and varied P.E curriculum as well as the chance to take on other roles within coaching and officiating.

**For more information please speak to Mr Hallett**

# GCSE Science Trilogy (Core)

## Overview

Learning about Science is important because:

- Science impacts on every aspect of our lives
- Science develops problem solving skills and team work
- Our country's future depends on it

All students must study Science in Years 9, 10 and 11. All students who do not pick Triple Science will complete GCSE Core Science in Year 9,10 and Year 11 to achieve two grades between 1-9. Higher tier (GCSE Grades 4 to 9 available) or the Foundation tier (GCSE Grade 1 to 5 available). This will be reviewed on a regular basis through assessment and monitoring of progress. Since 2016, GCSE Science has run in a linear style, with all examinations coming at the end of year 11. Science will continue to be awarded as **TWO** GCSE grades. Students can move onto A Level Sciences after following this route.

## Method of Assessment

The course is assessed by a total of six exam papers; two for biology, two for chemistry and two for physics. Each paper is out of 70 marks and is 1 hour and 15 minutes in duration. All examinations carry equal weighting. Within lessons, students will also carry out a range of required practicals.



## Course Content

### **Biology**

- Cell Biology
- Photosynthesis
- Moving and changing materials
- Health Matters
- Coordination and control
- Genetics
- Variation and evolution
- Ecology in action

### **Chemistry**

- Atomic Structure and the Periodic table
- Structure, bonding and properties
- Chemical quantities and calculations
- Chemical changes
- Energy changes
- The rate of chemical change
- Hydrocarbons
- Chemical analysis
- The atmosphere
- Sustainable development

### **Physics**

- Energy
- Electricity
- Particle model of matter
- Atomic structure
- Forces
- Waves
- Electromagnetism

**For more information please speak to Mrs Cook**

# GCSE French

## Why Study French?

A wise man once said, the 'One language sets you in a corridor for life, a second opens the doors along the way.' A GCSE in French opens all sorts of doors for you:

1. Learning a language develops a whole range of skills needed for the world of work. You enhance your memory, focus and interpersonal skills. Not only do you learn the foreign language, but you can also enhance your understanding of English as well.
2. Learning another language can improve your job opportunities – over 50% of companies rate French as useful to their organisation. With the changing political landscape, this is only going to increase.
3. It's fun! Traveling when you speak another language allows you to get a much deeper understanding of the culture. Once you have mastered one foreign language, it becomes much easier to master others.

## Course Content

- Introductory unit – 'Les Choristes' film study
- Identity and Culture
  - Family & friends, technology, media, healthy lifestyles.
- Local, national and international areas of interest
  - Where you live, travel, global issues and practical role plays
- Current and future study and employment.
  - Your school, schools in the French speaking world and plans for the future

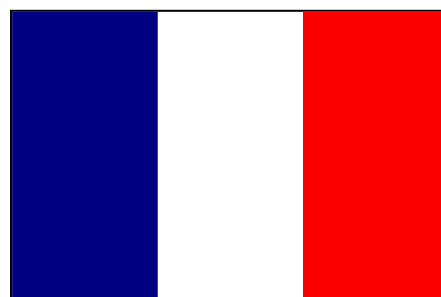

We learn through games and use authentic French resources like songs and films to bring the subject to life.

## Method of Assessment

French GCSE is assessed as four skills– listening, speaking, reading and writing – just as you have been assessed throughout Key Stage 3.

### Most of the grammar required for GCSE has been learnt by the end of Year 8.

100% of the course is exam based. The breakdown is as follows:

- |                  |     |
|------------------|-----|
| • Listening exam | 25% |
| • Speaking exam  | 25% |
| • Reading exam   | 25% |
| • Writing exam   | 25% |



# GCSE Geography

## Why Study Geography?

If you have an interest in the world you live in, the challenges it faces and your place within it, then read on. This modern and exciting course will deepen your understanding of geographical processes and illuminate the links between people and places. Geography enables young people to become globally and environmentally informed whilst also equipping them with a range of skills to support them in their further studies and career.

## Course Requirements

- The main requirement is that you have an interest in this subject.
- Secondly, that you are hardworking, keen and committed to this course.



## Method of Assessment

There are three assessments at the end of the two-year course; paper 1 and 2 are both worth 37.5% each and paper 3 is worth 25% of your total GCSE:

- **Paper 1: Global Geographical Issues**
- **Paper 2: UK Geographical Issues**
- **Paper 3: People and Environment Issues**

## Course Content

### **Topic 1 – Global Geographical Issues**

This will look at the challenges facing our planet such as hazardous events and climate change, poverty and development, urbanisation and megacities.

### **Topic 2 – UK Geographical Issues**

This will look at the physical and human processes which have shaped the country in which we live such as the evolving landscape and the changes to our rural and urban areas. You will complete independent research and a fieldwork study of an area. As part of the exam requirements, Geography GCSE includes an exciting Fieldwork opportunity where students visit a fieldwork centre and conduct in-depth investigation into rural and river environments.

### **Topic 3 – People and Environment Issues**

A decision making and synoptic topic which develops your knowledge and understanding of the interactions between people and environment at a variety of scales. You will be asked to reach your own justified conclusions about geographical issues.

**For more information please speak to Mrs Murdoch**

# GCSE History

## Why Study History?

At GCSE we build on prior knowledge and skills built up in Key Stage 3 and extend students understanding of History throughout a wide range of time periods and topics. These topics include Weimar and Nazi Germany 1918-1939 and Medicine through Time. In addition, you will learn about the power of Kingship in the early medieval period and the settlement of the American West in the 19<sup>th</sup> Century.

## Course Requirements

To be successful, you will need enthusiasm for History. Excellent reading and writing skills are also essential. During the course, you will be building on your existing historical skills, with an increased focus on source analysis and evaluating historical fact and opinion. An inquisitive mind comes in very useful!

Commitment, a positive approach and self-motivation are also vital, as independent study forms a key part of the course.

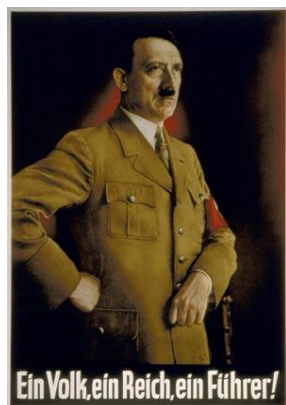
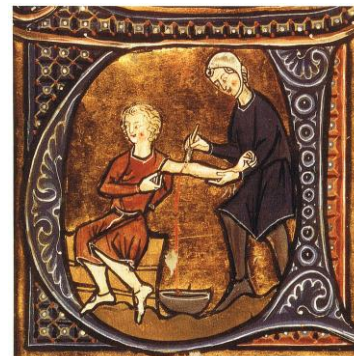

## Method of Assessment

Three examination papers:

- Paper 1- 30% - 1 hour 15 minutes
- Paper 2- 40% - 1 hour 45 minutes
- Paper 3- 30% - 1 hour 15 minutes



## Course Content

**Paper 1 – Medicine in Britain, c1250–present (Thematic Study) and The British sector of the Western Front, 1914–18: injuries, treatment and the trenches (Historic Environment Study).**

The changing nature of Medicine from the medieval era through to the present day. There is also an in depth study

**Paper 2 – The American West (Period Study) and Anglo-Saxon and Norman England, c1060–88 (British Depth Study).** Early settlement and development of the American West, treatment of the Plains Indians, conflict and conquest / The impact of the Norman invasion on England

**Paper 3 – Weimar and Nazi Germany, 1918-39 (Modern Depth Study).** Crisis in Germany after WW1, the rise of Hitler and life in Germany under Nazi control.

**For more information please speak to Mrs Murdoch**

# GCSE Art, Craft & Design

## Why Study Art, Craft & Design?

Creative thinking is a transferable skill and viewed favourably by any employer, no matter what the career area. Studying GCSE Art will provide you with a broad awareness of the relationship between Art & society in addition to enhanced fine motor skills, imaginative processes, aesthetic awareness, communication skills and problem solving qualities. These skills are vital in so very many roles, from Chef to Architect, Games Illustrator, Fashion Designer, Photographer. Creativity shows us how to think in new ways, be original and be valued. GCSE Art at Latimer has creativity embedded at the core and makes Art education a fun way to expand your knowledge and skills.

## Course Requirements

Learners must be motivated, committed and have an enjoyment of the subject. The workload is substantial and fast paced and requires independent thinking, but those who enjoy creativity and risk taking will really enjoy what the course has to offer.



## Method of Assessment

The portfolio of coursework constitutes 60% of the overall grade, the final exam establishing the other 40%. All submitted work is assessed internally by teaching staff and then moderated by a visiting member of the awarding body.

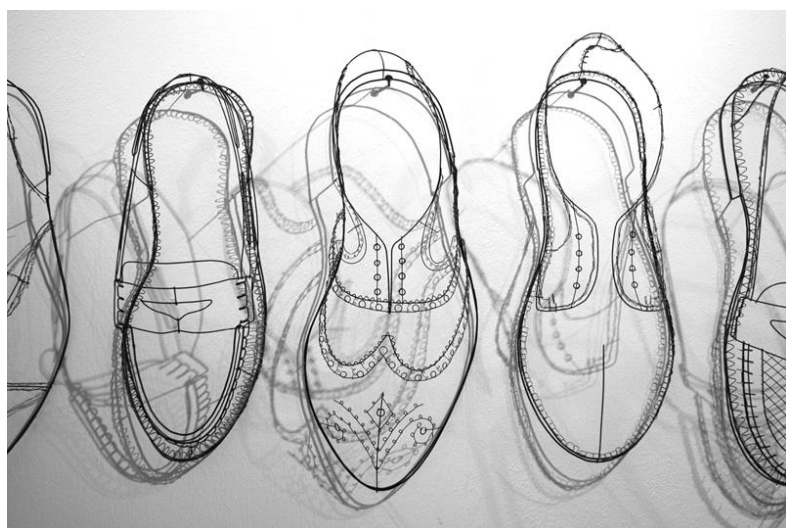

## Course Content

Students spend Year 9 and 10 building up a portfolio of coursework, encompassing some more extended and some shorter units of work, in addition to experimental workshops and skills based lessons. Units of work may focus on particular Art styles, movements, cultures, nominated artists or simply embrace materials, processes and techniques. Students will work in areas of study including Graphic communication, 3D design, Textile design, Photography and Fine Art and will become involved with independent research and enquiry throughout.

**For more information please speak to Mrs Ashcroft**

# GCSE Computer Science

## Why Study Computer Science?

Computing and computer technology are part of just about everything that touches our lives from the cars we drive, to the movies we watch, to the ways businesses and governments deal with us.

GCSE Computer Science explores the principles of digital technology and way of working that's called 'computational thinking', with coding as a core of the course. You have to be able to think logically, solve puzzles and be tenacious when the going gets tough. But it is also really creative and you'll get a real buzz out of getting something to work yourself, especially when programming.

## Course Content

### Unit 1 – Computer systems

- Systems Architecture
- Memory / Storage
- Wired and wireless networks
- Network topologies, protocols and layers
- System security
- System software
- Ethical, legal, cultural and environmental concerns

### Unit 2 – Computational thinking, algorithms and programming

- Algorithms
- Programming techniques
- Producing robust programs
- Computational logic
- Translators and facilities of languages
- Data representation

### Unit 3 – Programming Project

Learners will need to create suitable algorithms which will provide a solution to the problems identified in the task. They will then code their solutions in a suitable programming language. The solutions must be tested at each stage to ensure they solve the stated problem and learners must use a suitable test plan with appropriate test data.

- Programming techniques
- Analysis
- Design
- Development
- Testing and evaluation and conclusions



## Method of Assessment

**Unit 1 – Computer Systems** – Written Paper (1½ hours) 40% of total GCSE

**Unit 2 – Computational thinking, algorithms & programming** – Written Paper (1½ hours) 40%

**Unit 3 – Programming Project** – Practical coursework, controlled assessment (20 hours) 20%

**For more information please speak to Mr Morgan**

# GCSE Dance

## Why Study Dance?

*"It can speed up your heart rate, it can enliven your being, it can change your life"*

Richard Alston CBE

Dance is a powerful and expressive subject which will help develop creative, imaginative, physical, emotional and intellectual capacities. It will also help:

- to develop skills in performance, choreography and critical appreciation
- to develop confidence and self-esteem
- to promote fitness and well-being
- support learning across a range of subjects



## Course Content and Method of Assessment

There are two components in Dance GCSE:

### **Component 1 – Performance and choreography (60%)**

All work for this component is assessed by your teacher and moderated by an examiner.

#### **Performance (30%)**

- You will perform two set phrases (set by the exam board) through a 1 minute **solo** performance.
- You will also dance in a duet/trio performance lasting 3½ - 5 minutes. This will be choreographed in collaboration with your teacher.

#### **Choreography (30%)**

- You will choreograph **either** a solo or group dance where you must respond to an externally set stimulus and keep a choreographic log alongside a programme note about your dance.
- Solo (2-2 ½ minutes) Group (3-3 ½ minutes)

### **Component 2 – Dance appreciation (40%)**

You will complete a written examination, demonstrating knowledge of your own practice in performance and choreography and critical appreciation of 6 professional works. (1 hour 30 mins)

## The Future

GCSE Dance shows a prospective employer, school or college that you are a well-rounded individual with a wide variety of interests, who is able to work co-operatively and sensitively as part of a team. You will prove yourself to be a creative and critical thinker and this qualification might lead you into studying A Level Dance or alternative Dance courses.

**For more information please speak to Mrs Ilersic**



# GCSE Design & Technology

## Why Study Design & Technology?

The new GCSE places greater emphasis on understanding and applying iterative design processes. Students will use their creativity and imagination to design and make prototypes that solve real and relevant problems, considering their own and others' needs, wants and values.

## Course Requirements

An interest in designing is essential, with the ability to produce high quality graphic and practical work. Also required for success in this qualification are an aptitude to learn to work with design computer packages and a positive approach to independent study and the learning of theory content.



## Course Content

GCSE Design and Technology will prepare students to participate confidently and successfully in an increasingly technological world. Students will gain awareness and learn from wider influences on Design and Technology including historical, social, cultural, environmental and economic factors. Students will get the opportunity to work creatively when designing and making and apply technical and practical expertise. This GCSE allows students to study core technical and designing and making principles, including a broad range of design processes, materials techniques and equipment. They will also have the opportunity to study specialist technical principles in depth.

## Method of Assessment

**Unit 1** – A 2 hour written examination paper worth 50% of the GCSE grade

**Unit 2** – A Substantial design and make task worth 50% of the GCSE grade

Assessment criteria:

- Identifying and investigating design possibilities
- Producing a design brief and specification
- Generating design ideas
- Developing design ideas
- Realising design ideas
- Analysing & evaluating

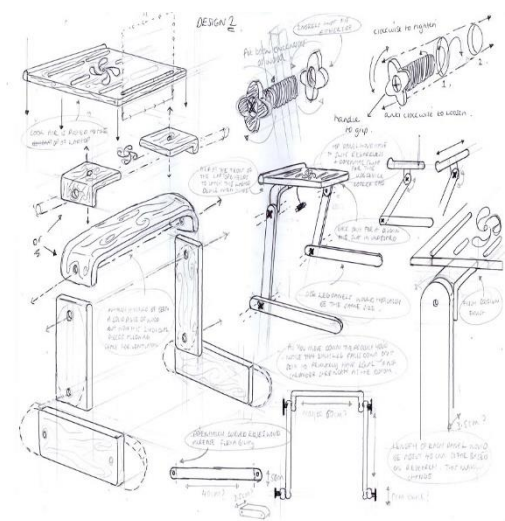

For more information please speak to Mrs Ashcroft

# GCSE Drama

## Why Study Drama?

Studying Drama is not just about acting and theatre; many employers in very different areas of work are encouraged by qualifications in Drama as the skills, developed through practical work, transfer well to all aspects of professional life. Self-confidence, presentation skills and the ability to work in groups are all transferable to the world of work. The GCSE Drama course is fun, challenging and a brilliant way to express your opinions through one of the most accessible performing arts.



## Course Content and Assessment

### **Component 1 – Understanding Drama**

Through the study of this unit, Drama students will learn and develop a range of key skills and strategies to assist them as they study and explore a play. Students will also analyse and evaluate the work of live theatre makers and will see live theatre as part of the course. This unit is assessed through an open book written examination and is worth 40% of the GCSE.

### **Component 2 – Devising Drama**

This unit explores the process of creating devised drama. Students will create original pieces for a performance. Practical workshops that explore different styles and practitioners from Stanislavski to Frantic Assembly will be undertaken. Students will work in groups to create their original piece and a devising log book will be created to support the practical work. This is an exciting and creative aspect of the course. This unit is assessed through a performance and devising log and is worth 40% of the GCSE.

### **Component 3 – Text in Practice**

This unit focuses on performance skills. Students will explore a play text and perform two extracts of this play for examination. The focus is on acting and performance, with an option to do design rather than acting if more desirable to the individual. This unit uses all of the skills gained over the course and is a really interesting and creative unit. This unit is assessed through performance and is worth 20% of the GCSE.



## The Future

The GCSE Drama course is the perfect preparation for further education, not just within the Performing Arts but across all courses where communication, creativity and team work is vital. It focuses on confidence, performance, project management and presentation skills which are fully cross-curricular and relevant to many occupations.

**For more information please speak to Ms Milson, Mr Goss or Ms Eyley**

# GCSE Food Preparation & Nutrition

## Why Study Food Preparation & Nutrition?

An engaging course that provides students with the opportunity to be inspired and excited about food whilst discovering more about food traditions, nutrition and diet. The course consists of an equal balance between practical cookery lessons and ICT-based theory lessons. Learners must be motivated, committed and have an enjoyment of all aspects of the subject.

## Course Requirements

- The course is heavily based on Scientific theory so those selecting this option must have consistently demonstrated a strong working grade in Science.
- Learners must have a knowledge of good health and safety practice.
- They must be able to demonstrate competence in a range of practical food skills, methods and processes to produce quality outcomes.

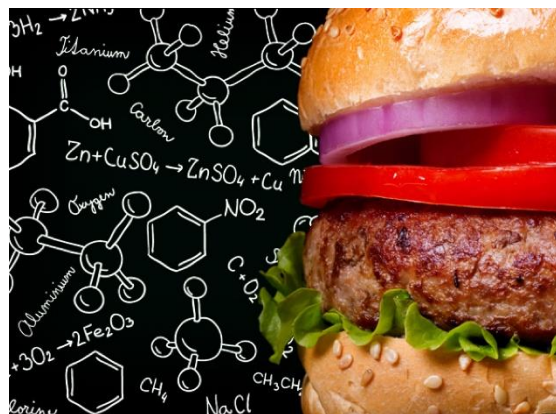

## Method of Assessment

- **Paper 1:** A written exam paper on theoretical knowledge of food preparation and nutrition accounts for 50% of overall GCSE mark.
- **Non-Exam Assessment:** A written Science investigation and electronic portfolio of practical work will account for the other 50% of the GCSE.

## Course Content



The course covers the broad field of food science and students will learn about the functional and nutritional properties of ingredients. Some of this learning will be carried out in a practical kitchen environment where students will have the facilities to investigate and experiment with recipes, techniques and processes.

The learning of food preparation skills will be integrated into five core topics:

- Food, nutrition and health
- Food science
- Food safety
- Food choice
- Food provenance

To reduce costs and meet food safety standards, the college will initially order the ingredients centrally for practical lessons. As students begin the NEA project they will be required to provide some of their own ingredients and recipes for practical lessons.

**For more information please speak to Mrs Ashcroft**

# GCSE Music

## Why Study Music?

- If you enjoy performing music and want to improve.
- If you enjoy creating your own music (on instruments or composing software) and want to learn more.
- If you enjoy being creative and want innovative lessons with independence and creative freedom.
- If you want to develop strong transferrable skills that are looked for by employers, universities and colleges.
- In recent research, results show that a student who typically takes nine GCSEs would expect to get a higher grade in one or two of their other subjects if they studied GCSE music, or a higher grade in at least three subjects if they achieved a graded instrumental/vocal music qualification at grade 4 or above.
- If you want to exercise your brain and become cleverer! Learning to read music and play an instrument/voice increases your IQ.



## Course Requirements

You need to be able to perform or have the motivation to work at and improve this skill. This can be on **any** instrument from voice to keyboard, guitar to drums and all the rest in between! You need to understand and enjoy most of your Year 8 Music lessons in order to be able to successfully access GCSE Music



## Course Content

- **AoS1 – Music YOU know and love**
- **AoS2 – The Orchestral Concerto**
- **AoS3 – Music around the World**
- **AoS4 – Film and Game music**
- **AoS5 – All things Pop Music**

## Method of Assessment

**Integrated Portfolio (practical coursework) 30%** – A performance and composition chosen by the student in **any** style.

**Practical Component (practical coursework) 30%** – Controlled conditions coursework: perform in a group and produce compositions based on set briefs.

**Listening and Appraising 40%** – 1 hour listening exam assessing knowledge and understanding from AoS2, 3, 4 and 5.

**For more information please speak to Ms Eyley**

# GCSE Philosophy & Ethics

## Why Study Philosophy & Ethics?

Philosophy and Ethics is a rich and diverse subject celebrating the beliefs, values and traditions of our multi-cultural society. The subject gives young people the opportunity to question the way they live and challenges the decisions they have to make; it is important for everyone, irrespective of personal beliefs. The course is designed to promote the spiritual, moral, cultural and social dimensions of the whole self.

Philosophy and Ethics deals very much with people and ideas and this helps where relationships are concerned throughout all aspects of life, e.g. school, home, work. The subject is particularly useful for careers involving working with people, not least medicine, teaching, social work and the emergency services. It can also open up areas of art, music, literature, film and drama which cannot be fully appreciated without an understanding of religion.

## Course Requirements

Students should be prepared to listen to others and see things from other people's point of view. Students should also be prepared to give their own justified opinion and construct a reasoned argument.



## Method of Assessment

Students will study units where religion can come into conflict with various aspects of life. There are three exams in Year 11 with equal weighting. **There is no coursework.**

## Course Content

Students will study three exams:

**Paper 1 – Philosophy and Ethics (50%) Paper 2 – Christianity (25%) Paper 3 – Islam (25%)**

Students will study a wide variety of topics that involve questioning the world that we live in. Some of the questions we will investigate are:

- Is abortion, euthanasia, suicide or animal experimentation wrong?
- When does life begin?
- Do we have the right to end life?
- Should marriage be forever?
- Can people justify divorce?
- Should contraception be allowed?
- Does God exist?
- What happens when we die?
- Is war always wrong?
- How should we treat criminals?
- Is the death penalty morally acceptable?
- Why is there suffering in the world?
- What is evil?

**For more information please speak to Mrs Murdoch**

# GCSE Physical Education (PE)

## Why Study PE?

If you are a fan of sports, a future PE teacher or someone who is enthusiastic about health and fitness, this is the course for you! The GCSE PE course offers exciting opportunities to be involved in a range of physical activities from team games to individual activities, allowing you the opportunity to demonstrate your performance whilst learning the key theory concepts too.



## Course Requirements

This course is best suited to students who have an **excellent** practical ability across a range of sports and have a keen interest to learn about the theory of the world of sport.

## Course Content

The theory work covers health, fitness, training, diet, body systems and the benefits of exercise. The teaching and learning of these topics is done both in the classroom and practically allowing you to understand ideas such as methods of training for improvement in sports, how the muscles and joints of the body work and the effect a certain diet can have on the body.

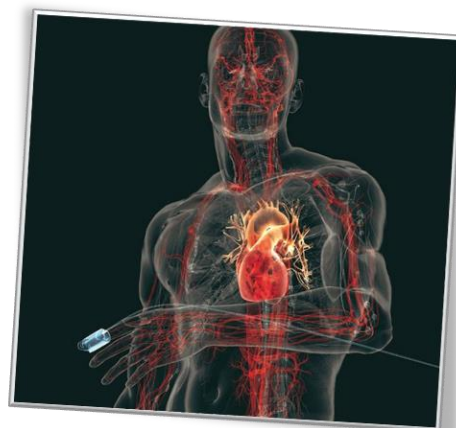

## Method of Assessment

The practical element of the GCSE course makes up 40% of your marks. After participating in a range of sports, your three best marks will be taken forward. One of these must be from a team sport, one from an individual sport and the third will come from either category. You will also submit an analysis and evaluation piece of coursework on your own performance.

60% of marks are from two theory exams taken at the end of Year 11.

This is a great opportunity to develop your sporting skills and learn more about the theory behind sport.

**For more information please speak to Mr Hallett**

# GCSE Psychology

## Why Study Psychology?

Ever wonder why someone becomes a criminal or why we forget where we have put our mobile phone down but can remember all the lyrics to our favourite songs? This engaging and exciting qualification seeks to answer questions about how our mind works and what affects our behaviour. Students will be introduced to the fundamentals of psychology, developing critical analysis, independent thinking and research skills. It looks at theories on behaviour and uses research to strengthen our understanding of the brain.

If you are interested in a career that means you will have to work with others then psychology could be of interest to you. Past psychologists have gone on to have successful careers in the police, sports, business and management as well as social services, education and healthcare.

## Course Content

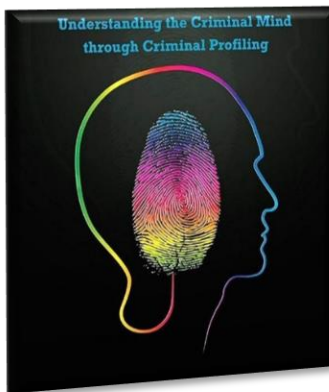

- In paper one, students will get to learn about psychological problems delving into why schizophrenia and depression may occur in individuals; criminal psychology and development, which looks at how behaviour and learning changes over our lifetime.
- In paper two, students will look at social influence, covering concepts such as group and crowd influences on obedience and conformity. Students will also learn about memory and sleep and dreaming, getting the opportunity to analyse their own dreams.
- Research methods is an integral part of psychology and is how psychologists conduct research, this is covered across both papers.



## Method of Assessment

There will be two 1 hour 30 minute written exams at the end of the course. Each is worth 50% of the GCSE.

Assessment is through multiple choice questions, short answer questions and extended writing questions.

**For more information please speak to Miss Tidmarsh**

# GCSE Science Triple Award

## Why Study Science Triple Award?

Due to the demands and content of this course, students should only consider this pathway if they:

- Have excelled in Science throughout Key Stage 3.
- Have a genuine aim of studying one or more Science subjects at A Level.
- Have ambitions of undertaking a career in a Science-based area.

By taking Triple Science, students study the individual subjects of Biology, Chemistry and Physics and will gain **THREE** GCSEs. Higher tier (GCSE Grades 4 to 9 available) or the Foundation tier (GCSE Grade 1 to 5 available). This will be reviewed on a regular basis through assessment and monitoring of progress.

## Course Requirements

Students should have an avid interest in science and should be performing at or above their target level. Students need to have their suitability for the course confirmed by Mrs Cook.

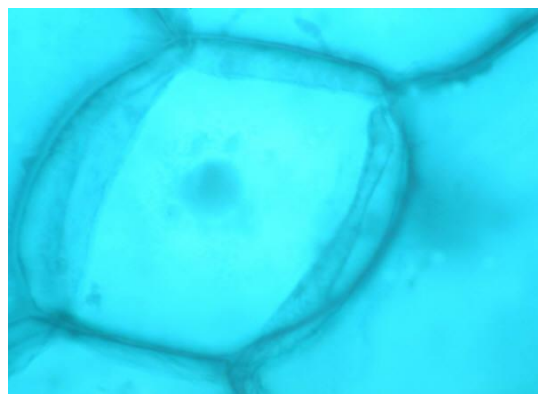

## Method of Assessment

Triple award will result in the students obtaining separate GCSEs in Biology, Chemistry and Physics. Each of these GCSEs is made up of:

- 100% External examinations - two x 1 hour 45 mins per subject
- With compulsory scientific investigations in lessons.

## Course Content

Each of the separate GCSEs is broken down into a number of subject-specific units to be completed over the three years of study. See your Science teacher for more details about these units.

Triple award scientists will use their Science Trilogy (Core) time from the core column and must state a preference for Triple Science in the option column.

Year 9 teachers will discuss with individual students the most appropriate route for them.

**For more information please speak to Mrs Cook**



# BTEC Business

## Why Study BTEC Business?

This course will provide an engaging and stimulating introduction to the world of Business. Learners will develop key enterprise and financial skills and knowledge necessary to enable them to understand how businesses recognise opportunities and build on them to succeed. Learners will understand how a business makes and manages its money and plans for the future. This course will encourage learners to develop their people, communication, planning and team-working skills, all of which are essential skills when working in a business environment.



## Course Requirements

Students who opt for this course believing it is “easy” will have a huge shock. There will be a huge amount of pressure on students to meet strict deadlines and to complete work in their own time.

Students who choose this course must show a high level of commitment and dedication; they must have a strong interest in the Business world and how businesses are run; they must also have an interest in keeping up to date with current affairs and the news.

## Method of Assessment

This is a vocational qualification where learners develop knowledge and understanding by applying their learning and skills in a work-related context.

Two out of the three units will be assessed in the form of Pearson set assignments, made up of a combination of written work, presentations, role plays and practical assessment.

The third unit will take the form of a written exam where students will be tested on their knowledge of promotion and finance.

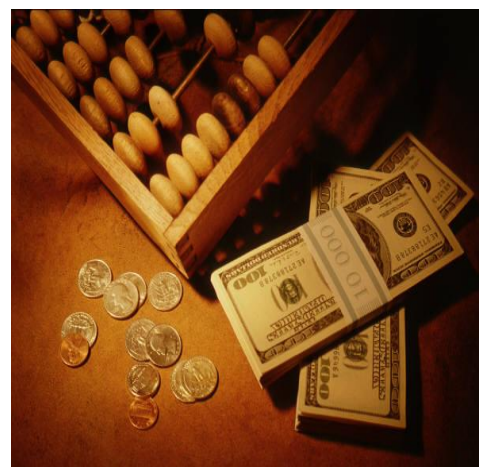

## Course Content

In Unit 1, you will plan an idea for a realistic business start-up in your local area, based on research. You will then present the business model and plan.

In Unit 2, you will explore the types of cost that businesses incur, from start-up to running costs. You will then explore the ways in which the sales of products and services generate revenue so you can develop your understanding of profit.

**For more information please speak to Mr Arnold**

# BTEC Creative Digital Media Production

## Why Study BTEC Creative Digital Media Production?

We are bombarded with images; a huge variety of information through media such as TV, social networking, film, advertising and music. This course enables you to understand this language; to become empowered and aware. This course is designed to make you think more deeply about how media texts affect us all.

You will study a variety of digital media sectors such as Publishing, Websites and Moving Image, discovering how they shape opinion and influence audiences.

## Method of Assessment

This is a vocational qualification where learners develop knowledge and understanding by applying their learning and skills in a practical context.

Two out of the three units will be assessed in the form of Pearson set assignments, made up of a combination of written work, presentations, role plays and practical assessment.

The third unit will take the form of a controlled assessment in which students will be required to plan and create a piece of work which fits a client brief.

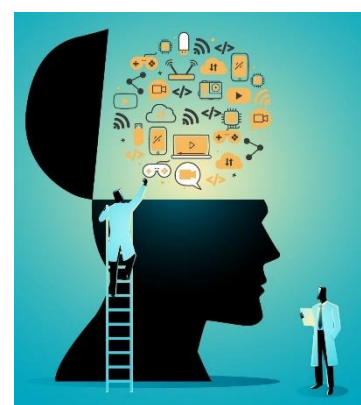

## Course Content

**Digital Media Sectors and Audiences** – in this unit learners will explore the digital media industry and all five key sectors that fall under it (Digital Moving Image, Digital Audio Production, Digital Publishing, Website Production and Digital Games Production). They will also explore the different types of audiences and how audiences can engage with each sector.

**Planning and Pitching a Digital Media Product** – in this unit learners will use their verbal, written and visual communication skills to enable them to formulate, develop and pitch ideas of a product that they then plan to produce.

**Digital Moving Image Production** – in this unit learners will investigate key features of digital moving image productions, including structures, generic conventions and audience address, in preparation for the making of a film or video.

**Digital Publishing Production** – in this unit, learners will gain the knowledge and skills required for the design and development of digital publishing products. They will also have an overview of how to source materials and then combine them. Learners will organise and manage the production of a digital publishing product.

**For more information please speak to Miss Mistry**

# BTEC Sport

## Why Study BTEC Sport?

For sports lovers and budding coaches, future PE teachers or someone who is enthusiastic about health and fitness, this is the course for you!

The BTEC Sport course offers the opportunity to develop leadership skills, knowledge of fitness and combines both theory and practical elements of sport.

## Course Requirements

This will suit anyone with an interest in the world of sport who is well motivated. Students also need to have an interest in learning about the theory behind successful performance.



## Course Content

Students will have four lessons per fortnight, in addition to normal PE lessons. They will cover 3 Units on the course.

**Unit 1: Preparing Participants to Take Part in Sport and Physical Activity.** Students will learn about the different provision for sport, barriers to participation and ways to warm-up for exercise.

**Unit 2: Taking Part and Improving Other Participants' Sporting Performance.** Students will look at components of fitness, roles of officials and plan ways to improve performance.

**Unit 3: Developing Fitness to Improve Other Participants' Performance in Sport and Physical Activity.** Students will learn the importance of fitness in physical activity and will develop an understanding of the body and fitness testing.

## Method of Assessment

There are 3 Units covered on the course with grades from all 3 contributing to their overall grade. Unit 1 and Unit 2 are assessed through a 5 hour controlled assessment under exam conditions.

Unit 3 is assessed through a 1.5 hour external assessment.



**If you are interested in playing sport and learning more about the theory behind sport and exercise, then this is the course for you!**

**For more information please speak to Mr Hallett**